

DATE REVISED	DATE FILMED	DATE REVISED	DATE FILMED	FED. ROAD DIST. NO.	STATE	FED. AID PROJ. NO.	SHEET NO.	TOTAL SHEETS
04-10-2003				6	ARK.			
JOB NO.							1	
RIP. & EXCAV.							1891F	

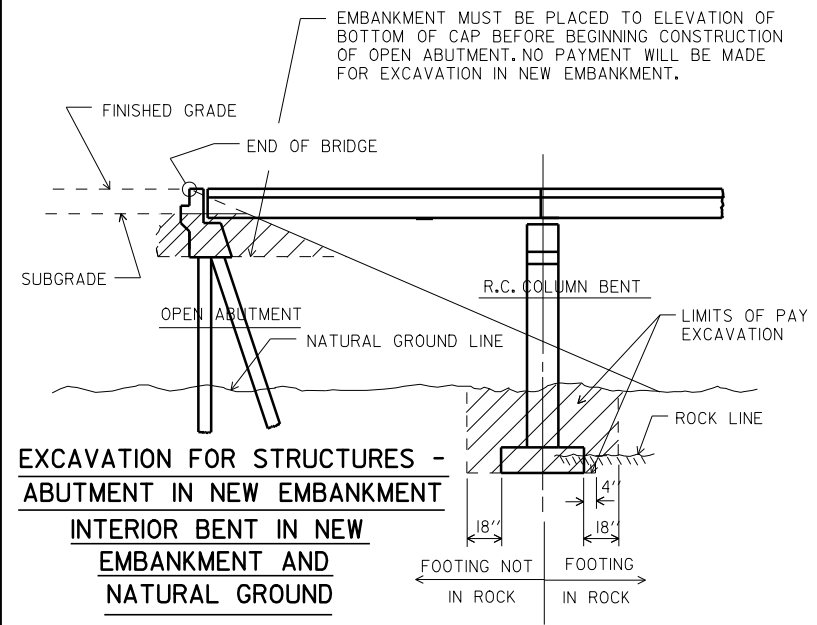

**EXCAVATION FOR STRUCTURES - ABUTMENT IN NEW EMBAKMENT INTERIOR BENT IN NEW EMBAKMENT AND NATURAL GROUND**

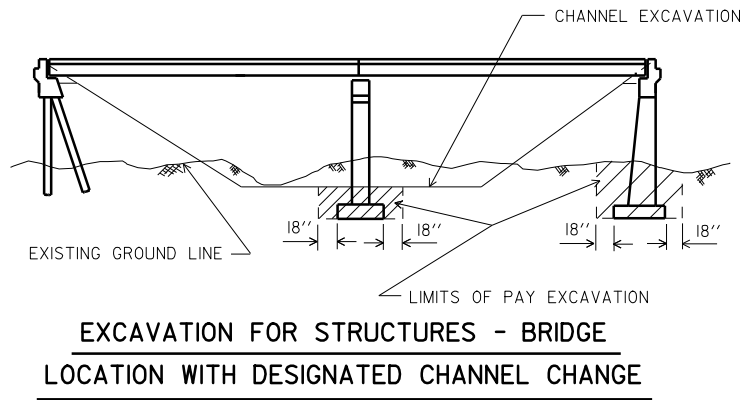

**EXCAVATION FOR STRUCTURES - BRIDGE LOCATION WITH DESIGNATED CHANNEL CHANGE**



**PLAN OF DUMPED RIPRAP**

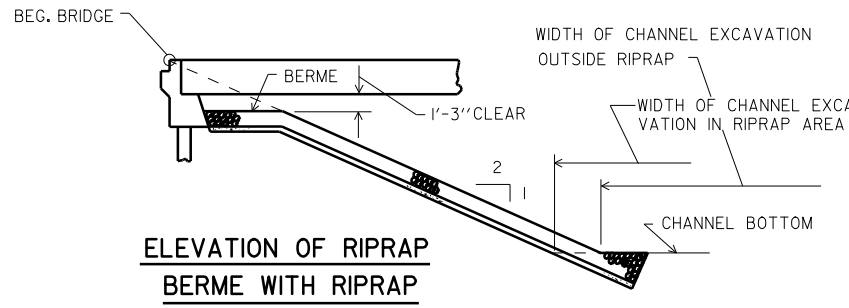

**ELEVATION OF RIPRAP BERME WITH RIPRAP**

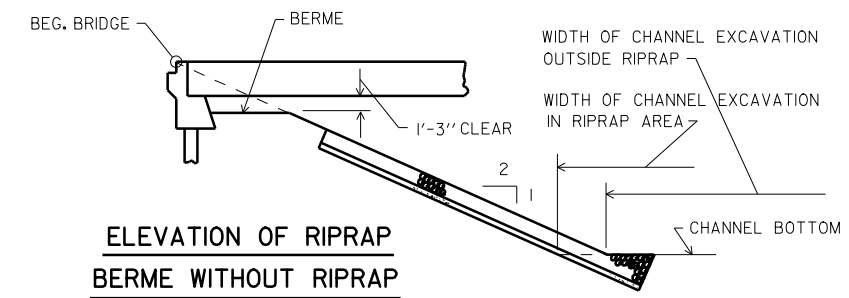

**ELEVATION OF RIPRAP BERME WITHOUT RIPRAP**

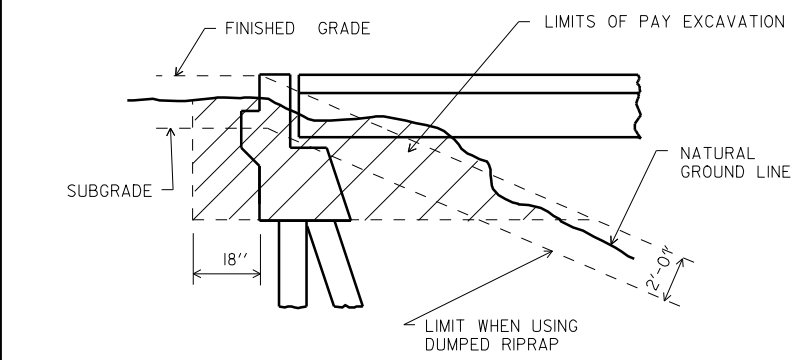

**EXCAVATION FOR STRUCTURES - ABUTMENT IN NATURAL GROUND**

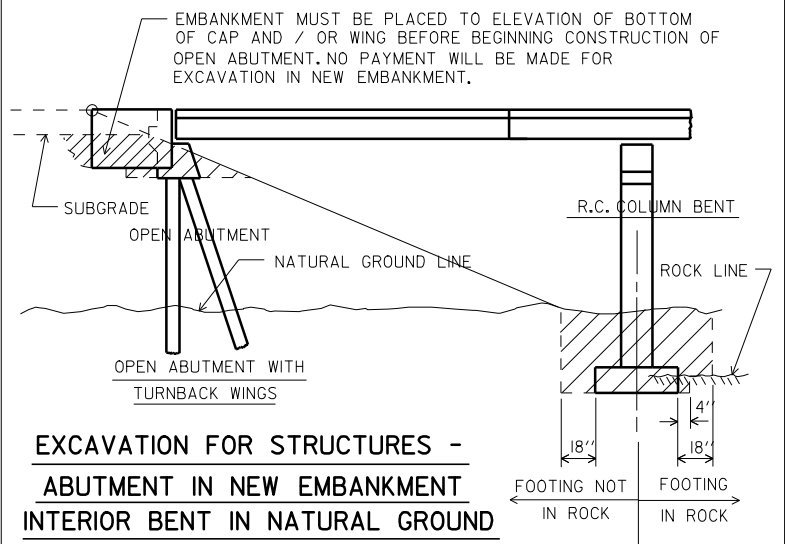

**EXCAVATION FOR STRUCTURES - ABUTMENT IN NEW EMBAKMENT INTERIOR BENT IN NATURAL GROUND**

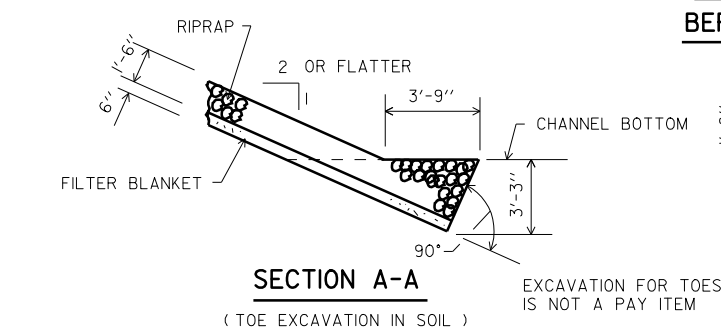

**SECTION A-A (TOE EXCAVATION IN SOIL)**

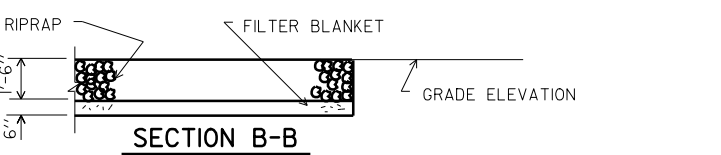

**SECTION B-B**

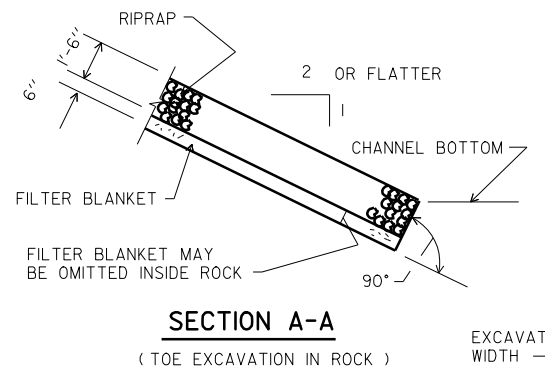

**SECTION A-A (TOE EXCAVATION IN ROCK)**

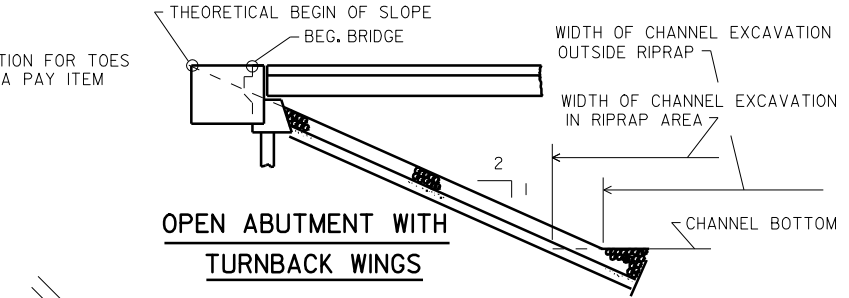

**OPEN ABUTMENT WITH TURNBACK WINGS**

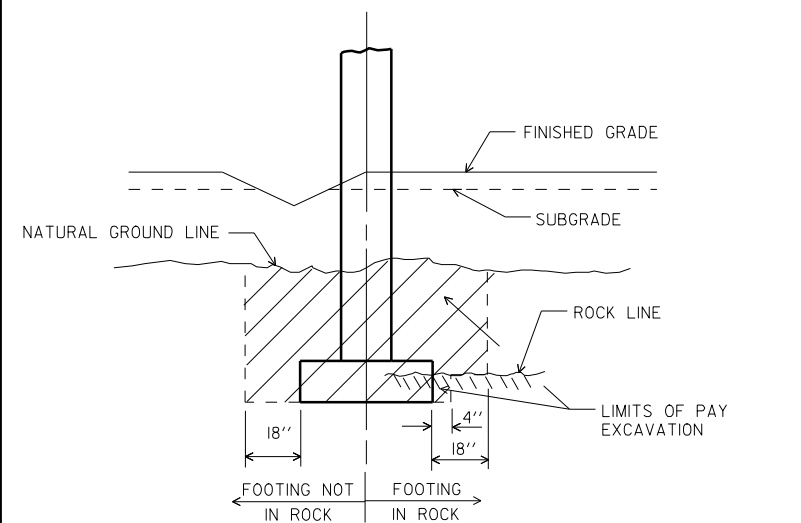

**EXCAVATION FOR STRUCTURES - BENT IN ROADWAY FILL SECTION AND NATURAL GROUND**

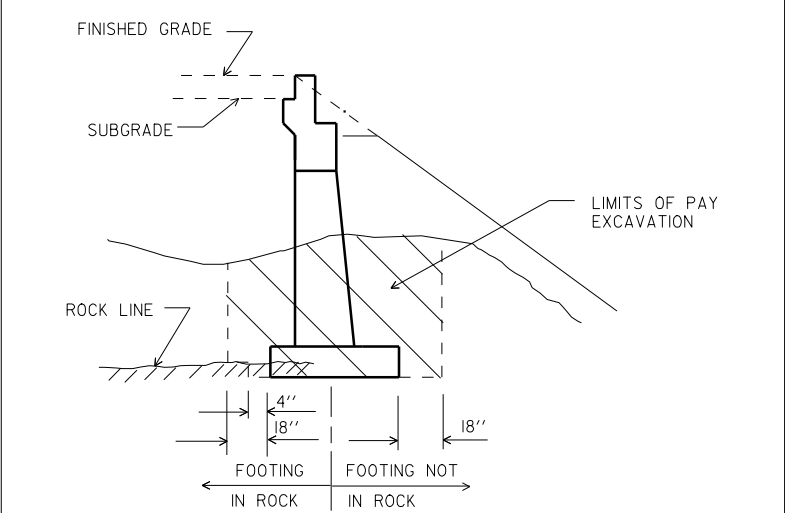

**EXCAVATION FOR STRUCTURES - ABUTMENT IN NATURAL GROUND AND NEW EMBAKMENT**

NOTE : USE THIS TYPE OF TOE WHEN ROCK IS ENCOUNTERED WHICH IS IN A STABLE CONDITION.

NOTE : IN LIEU OF AN AGGREGATE FILTER BLANKET, A SYNTHETIC FIBER GEOTEXTILE FABRIC COMPLYING WITH THE REQUIREMENTS OF SUBSECTION 816.02(e) MAY BE USED.

NOTE : DETAILS FOR COMPUTING EXCAVATION FOR STRUCTURES ARE INCLUDED FOR INFORMATION AS TO HOW PLAN QUANTITIES WERE CALCULATED AND FOR USE WHEN ADJUSTING QUANTITIES WHEN CHANGING FOOTING ELEVATION.

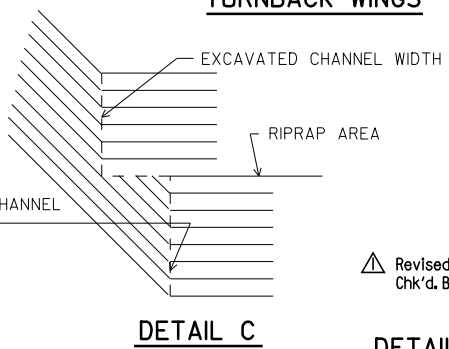

**DETAIL C**

Revised and redrawn MJT 04-10-2003  
Chk'd. By: CJF 04-10-2003

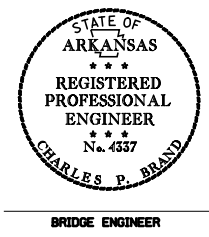

**DETAILS FOR DUMPED RIPRAP AND FILTER BLANKET AND DETAILS FOR COMPUTING EXCAVATION FOR STRUCTURES**  
ROUTE SEC.  
**ARKANSAS STATE HIGHWAY COMMISSION**  
LITTLE ROCK, ARK.  
DRAWN BY: MJT DATE: 04-10-2003 FILENAME: B1891F.STD  
CHECKED BY: CJF DATE: 04-10-2003 SCALE: NO SCALE  
DESIGNED BY: STD. DATE: \_\_\_\_\_  
BRIDGE NO. DRAWING NO. 1891F