

DATE REVISED	DATE FILMED	DATE REVISED	DATE FILMED	FED. RD. DIST. NO.	STATE	FED. AID PROJ. NO.	SHEET NO.	TOTAL SHEETS
				6	ARK.			

2 SIGNALIZATION DETAILS

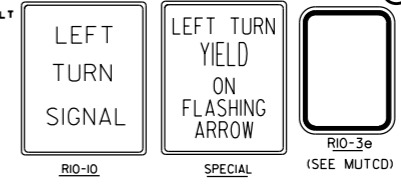
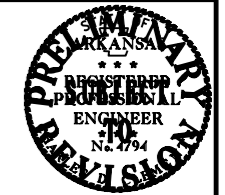

RI0-3e (SEE MUTCD)

NOTES:  
EACH ITEM "TRAFFIC SIGNAL HEAD (4 SEC., 1-WAY)" SHALL INCLUDE A SPECIAL SIGN AS SHOWN, ATTACHED TO THE MAST ARM OR SPAN ASSEMBLY 12" TO THE RIGHT OF THE SIGNAL HEAD UNLESS REMOVED WITHIN SIGNAL PLAN NOTES.

SIGN BLANK SHALL BE CONSTRUCTED OF ALUMINUM ALLOY (ASTM DESIGNATION B-209, ALLOY 5052-H38) WITH A THICKNESS OF 0.100 INCH.

SIGN FACE SHALL BE CONSTRUCTED OF HIGH INTENSITY SHEETING (TYPE III) WITH SILKSCREEN LEGEND AND BORDER.

EACH ITEM "TRAFFIC SIGNAL HEAD (3 SEC., 1-WAY)", TO BE USED AS A LEFT TURN INDICATION ONLY, SHALL INCLUDE A SIGN (RIO-10) AS SHOWN, ATTACHED TO THE MAST ARM OR SPAN ASSEMBLY 12" TO THE RIGHT OF THE SIGNAL HEAD.

TETHER STRAND SHALL BE EITHER 5\*32" OR 3\*16" HIGH FATIGUE STAINLESS STEEL AIRCRAFT CABLE IN 7/19 CONFIGURATION, MIL-W-83420 CERTIFIED, WITH A MINIMUM STRENGTH OF 2400 LB.

SIGNAL OPERATION NOTES:

FLASHING OPERATION - PRIOR TO NORMAL OPERATION, SIGNAL SHALL BE FLASHED FOR A PERIOD OF 3 TO 5 WORK DAYS. SIGNAL SHALL BE PLACED IN OPERATION ONLY ON A REGULAR WORK DAY, EXCEPT FRIDAY.

THE CONTRACTOR MAY BE REQUIRED TO ALTER THE FLASHING DISPLAY DURING THE TEMPORARY FLASH PERIOD. AT THE TIME THE INTERSECTION IS PLACED IN PERMANENT OPERATION, THE FLASH SEQUENCE SHALL THEN BE RETURNED TO THAT INDICATED ON THE PLAN SHEETS. NO ADDITIONAL COMPENSATION SHALL BE ALLOWED FOR THESE ALTERATIONS IN FLASH SEQUENCE.

FOUNDATION NOTES

1. ALL REINFORCING STEEL SHALL BE GRADE 40 MINIMUM.
2. SPAN WIRE POLES WITH A 9" OR 10" POLE BASE SHALL USE FOUNDATIONS THAT ARE 30" IN DIA. AND 9'-0" IN DEPTH. VERTICAL REINFORCING SHALL BE 12-\*7 @ 102". HORIZONTAL REINFORCING STEEL SHALL BE 13-\*4 @ 8.333" O.C.
3. SPAN WIRE POLES WITH AN 11", 12" OR 13" POLE BASE SHALL USE FOUNDATIONS THAT ARE 30" IN DIA. AND 12'-0" IN DEPTH. VERTICAL REINFORCING STEEL SHALL BE 12-\*7 @ 138". HORIZONTAL REINFORCING STEEL SHALL BE 17-\*4 @ 8.5" O.C.
4. ALL PED POLES SHALL USE FOUNDATIONS THAT ARE 30" IN DIAMETER AND 7'-0" IN DEPTH. VERTICAL REINFORCING STEEL SHALL BE 12-\*7 @ 78". HORIZONTAL REINFORCING STEEL SHALL BE 10-\*4 @ 8.44" O.C.

MINIMUM STRUCTURAL REQUIREMENTS:  
DESIGN SPECIFICATIONS: AASHTO STANDARD SPECIFICATIONS FOR STRUCTURAL SUPPORTS FOR HIGHWAY SIGNS, LUMINAIRES AND TRAFFIC SIGNALS, 4TH EDITION (2001) WITH 2003 AND 2006 INTERIMS.

USE FATIGUE CATEGORY II.

CONSTRUCTION SPECIFICATIONS: ARKANSAS STATE HIGHWAY AND TRANSPORTATION DEPARTMENT STANDARD SPECIFICATIONS FOR HIGHWAY CONSTRUCTION (2003 EDITION) WITH APPLICABLE SUPPLEMENTAL SPECIFICATIONS AND SPECIAL PROVISIONS.

BASE WIND SPEED: 90 MPH

STEEL MEMBERS CONSIDERED MAIN LOAD CARRYING MEMBERS WITH THICKNESS GREATER THAN 1/2" SHALL MEET THE LONGITUDINAL CHARPY V-NOTCH TEST SPECIFIED IN SUBSECTION 807.05 OF THE STANDARD SPECIFICATIONS.

DATE	REVISION	DATE FILM
7-21-11	REVISED PEDESTRIAN SIGN & GROUNDING	
5-21-09	REVISED GROUNDING	
9-10-08	REV. STEEL AIRCRAFT CABLE CONFIGURATION NOTE	
7-31-08	REVISED GROUNDING	
4-18-08	REVISED AASHTO NOTES	
4-17-08	REVISED TO 2001 AASHTO STANDARDS	
10-12-04	REV. CABINET ORIENTATION & SIGNAL OPERATION	
5-22-02	REVISED	
12-27-99	REVISED	
11-18-98	REVISION TO NOTES	
11-21-95	ISSUED	

ARKANSAS STATE HIGHWAY COMMISSION

SIGNALIZATION DETAIL  
(Span Wire Assembly Steel Pole)

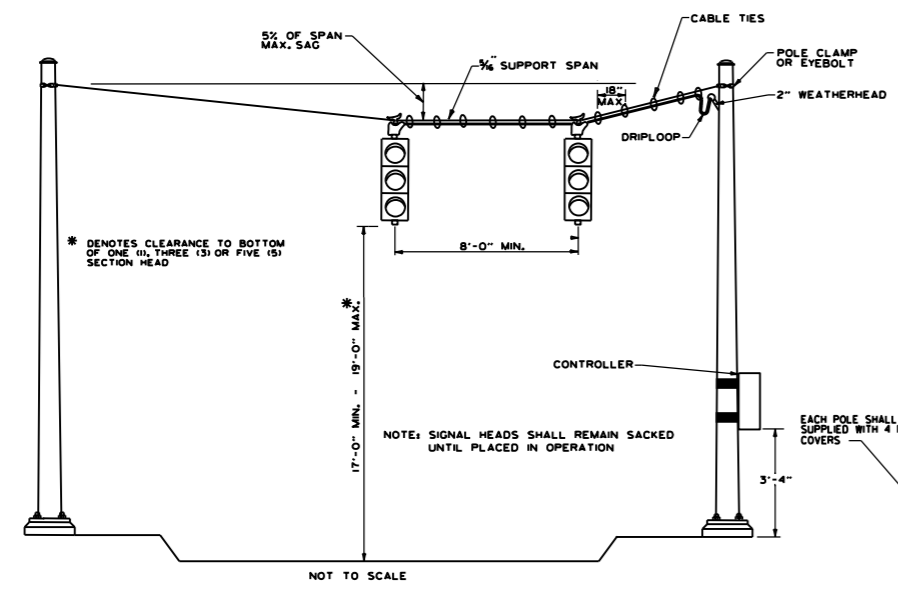

TYPICAL SPAN WIRE ASSEMBLY

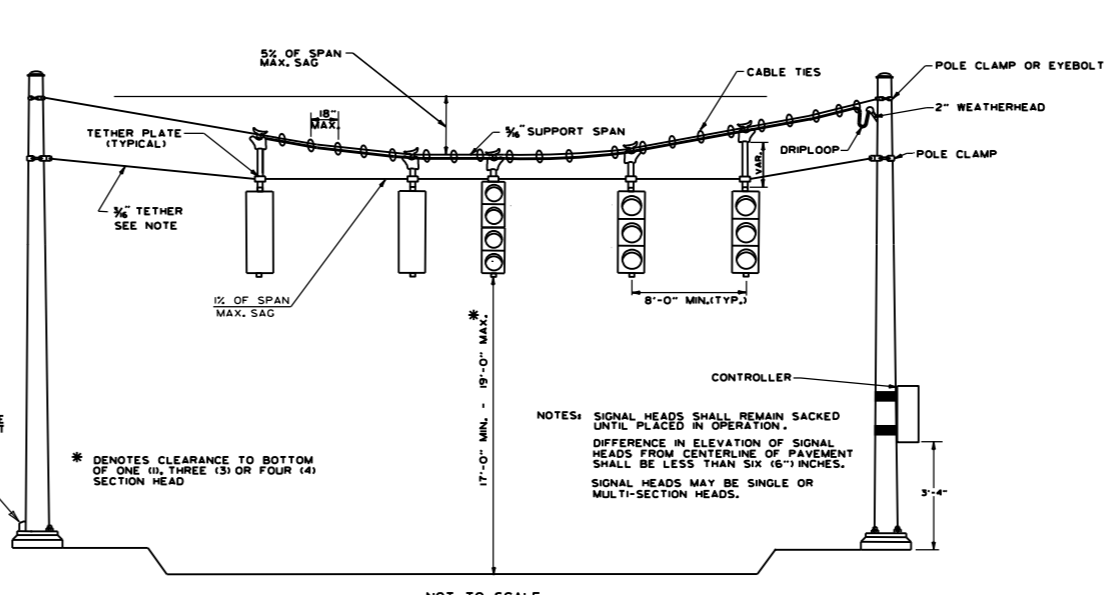

TYPICAL SPAN WIRE ASSEMBLY WITH TETHER

NOTES: SPAN WIRE POLES SHALL BE MOUNTED A MINIMUM OF 4' BEHIND CURB OR SHOULDER.  
OCTAGONAL POLES AND ARMS MEETING THE REQUIREMENTS OF THE PLANS AND SPECIFICATIONS CAN BE INSTALLED IN LIEU OF ROUND POLES AND ARMS. ALL POLES AND ARMS IN A JOB MUST BE OF THE SAME SHAPE.  
SPAN WIRE ASSEMBLIES WILL REQUIRE TETHER UNLESS OTHERWISE NOTED ON PLAN SHEETS.  
CABLE TIES SHALL BE SUITABLE FOR OUTSIDE USE (BLACK).  
THE ANCHOR BOLTS AND SWEEPING "L" CONDUIT SHALL BE PLACED IN THE FOUNDATION IN ACCORDANCE WITH THE MANUFACTURER'S SPECIFICATIONS. THE FOUND ROD SHALL EXTEND A MINIMUM OF 8' BELOW CABINET FOUNDATION.  
THE CONTROLLER POWER SUPPLY GROUND BUSS SHALL BE BONDED TO THE FOUNDATION GROUND ROD WITH A #8 AWG SOLID COPPER WIRE. ON EXISTING FOUNDATIONS WITH NO GROUND ROD, CONTRACTOR SHALL INSTALL A 10' x 5/8" COPPERWELD GROUND ROD.

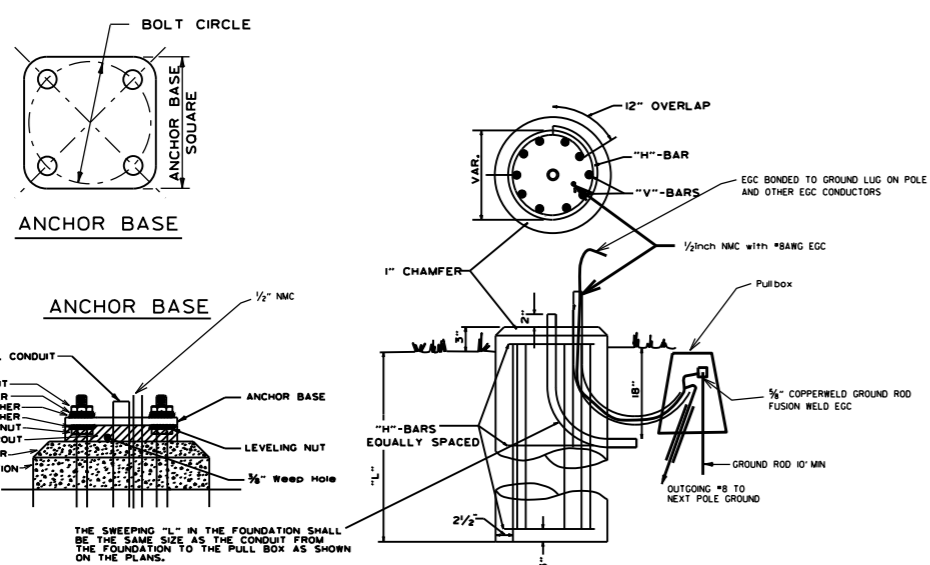
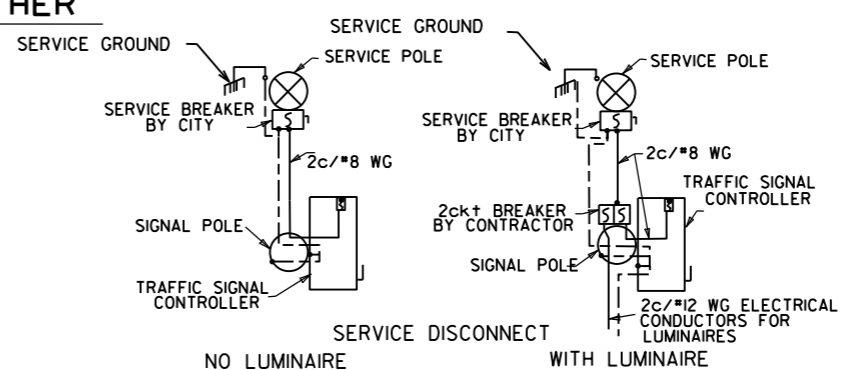
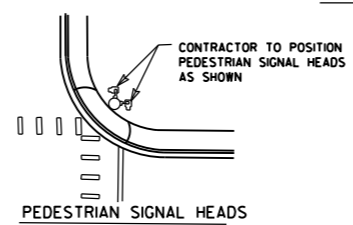

TYPICAL FOUNDATION DETAILS

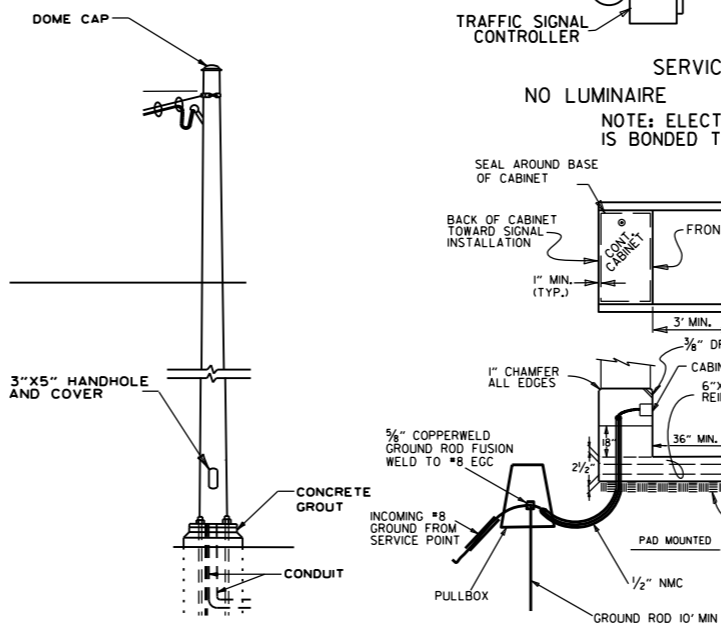

SPAN WIRE ASSEMBLY WITH SPAN WIRE SUPPORT POLE

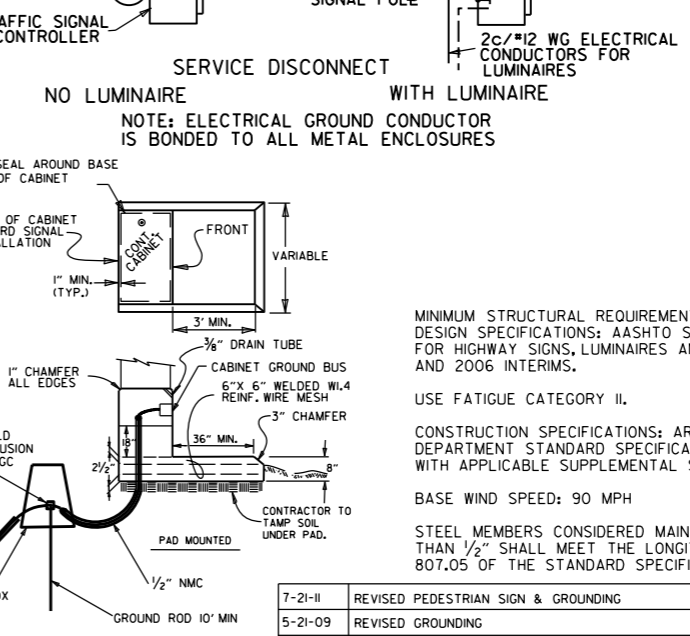

CONCRETE BASE MOUNTED CABINET DETAILS

UNLESS OTHERWISE DIRECTED BY THE ENGINEER, CABINET ORIENTATION SHALL BE SUCH THAT THE BACK OF THE CABINET IS PARALLEL TO THE STREET AND POSITIONED TO ALLOW VISIBILITY OF THE SIGNAL DISPLAY WHILE OBSERVING THE CONTROLLER FRONT PANEL.

GROUND ROD - A 10' X 5/8" GROUND ROD SHALL BE INSTALLED IN THE PULL BOX FOR EACH POLE AND THE CONTROLLER. PAYMENT FOR THE GROUND ROD AND 1/2" NMC SHALL BE INCLUDED IN ITEM 713 FOR SIGNAL POLES AND ITEM 701 FOR THE CONTROLLER. THE PULL BOX AND EGC CONDUCTOR SHALL BE PAID FOR SEPARATELY.

ALL CONCRETE SHALL BE CLASS "S" WITH A MINIMUM 28 DAY COMPRESSIVE STRENGTH F'c=3500 PSI. CONCRETE SHALL BE POURED IN THE DRY AND ALL EXPOSED CORNERS CHAMFERED 3/4" UNLESS NOTED OTHERWISE.

ALL REINFORCING STEEL SHALL CONFORM TO AASHTO M31OR M53, GRADE 40 (YIELD STRENGTH=40,000 PSI).

stdsd3.dgn