

**DELINEATOR PLACEMENT**

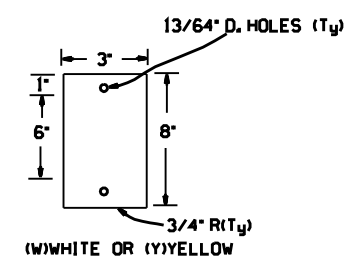

NOTE: DELINEATORS ARE TO BE MOUNTED TO POST USING PIN AND COLLAR (FASTENERS) WHICH ARE 6061 ALLUM. ALLOY, PIN LENGTH SHOULD NOT EXTEND FURTHER THAN 1/8" PAST THE COLLAR. TYPE 2 DELINEATOR CONSIST OF 2 REFLECTORS MOUNTED BACK-TO-BACK ON A SINGLE POST.

**TYPE 1 & 2 DELINEATORS**

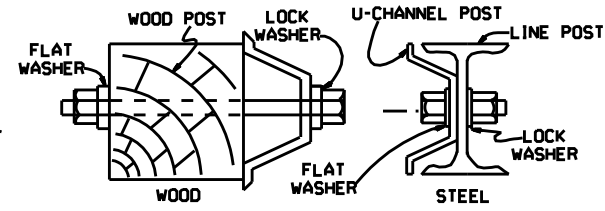

NOTE: USE 3/8" D. HEX. HEAD BOLT AND NUT (A307) WITH 1 FLAT WASHER AND 1 LOCK WASHER. BOLT, NUT AND WASHERS TO BE GALV. (AASHTO M 232) BOLT SHALL NOT EXTEND MORE THAN ONE (1) BOLT DIA. PAST NUT.

**DELINEATOR POST DETAIL**

NOTE: IN LIEU OF THE U-CHANNEL DELINEATOR POST THE CONTRACTOR SHALL HAVE THE OPTION OF EXTENDING THE GUARD CABLE LINE POST 1'-0" TALLER WHERE DELINEATOR POSTS ARE REQUIRED. FOR WOOD POSTS, DELINEATORS MAY BE MOUNTED ON THE ANCHOR POSTS AT SPECIFIED INTERVALS.

**ELEVATION**

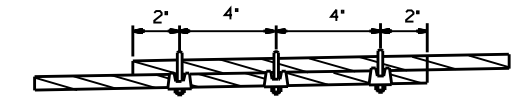
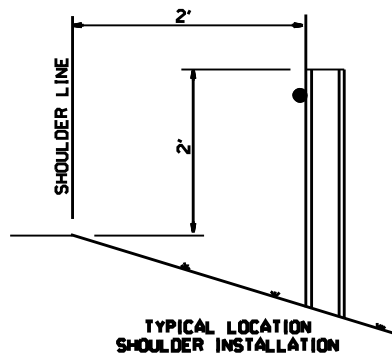
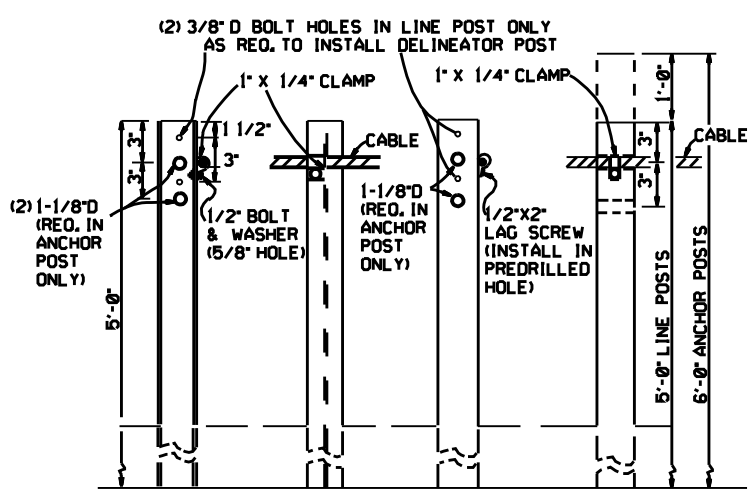

ONLY ONE SPLICE PERMITTED BETWEEN ANCHORS, LOCATED BETWEEN LINE POSTS ONLY. SPLICES WILL NOT BE PERMITTED IN SPANS ADJACENT TO THE ANCHOR AND CABLE END ASSEMBLIES. GUARD CABLE GREATER THAN 300 FEET IN LENGTH REQUIRES AN INTERMEDIATE ANCHOR AS SHOWN.

**SPLICE DETAIL**

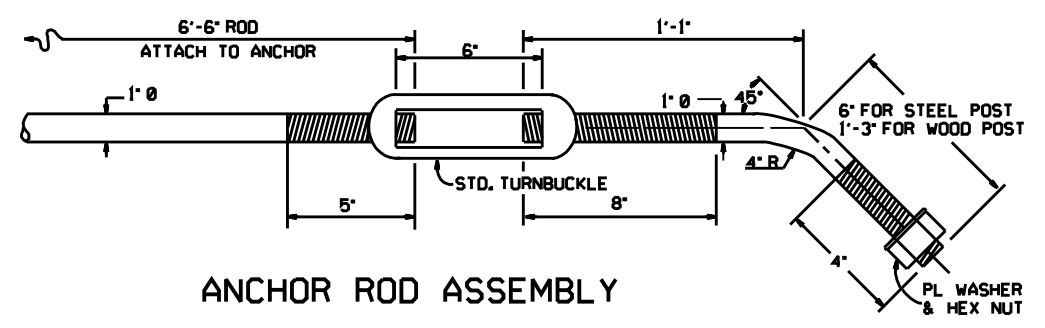

**ANCHOR ROD ASSEMBLY**

**STEEL POST**  
S 3 X 5.7 OR  
WELDED BEAM CONSTRUCTION (ASTM A769)

**WOOD POST**  
3 1/2" X 3 1/2" SQUARE (4X4 NOMINAL) OR 4" ROUND SOUTHERN PINE INSPECTION BUREAU, TIMBER, NO. 1 1350 f SOUTHERN PINE OR WEST COAST LUMBER INSPECTION BUREAU, POSTS AND TIMBERS DENSE NO. 1 STRUCTURAL OR BETTER 9.7 f (1400f).

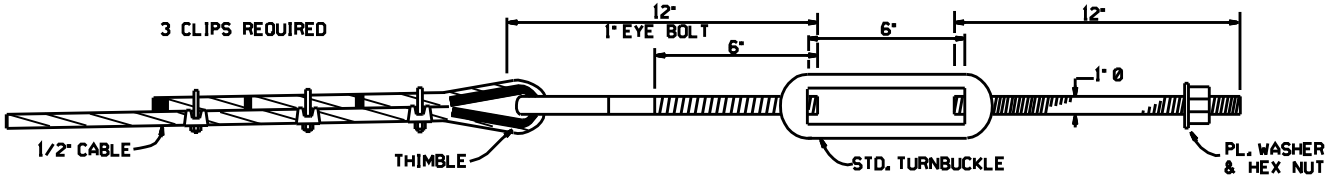

**CABLE END**

**POST DETAILS**

NOTE: POST MAY BE WOOD OR STEEL. IN GENERAL, ONLY ONE MATERIAL WILL BE ALLOWED WITHIN A SINGLE PROJECT. HOWEVER, WITH APPROVAL OF THE ENGINEER, POSTS MAY BE MIXED ON A JOB PROVIDED DEFINITE LIMITS ARE ESTABLISHED AND ALL POSTS ARE OF THE SAME TYPE WITHIN THOSE LIMITS. ONLY ONE TYPE POST MAY BE USED WITHIN A SINGLE ASSEMBLY.

DATE	REVISION	FILMED
10-18-96	REV. ASTM REF. TO AASHTO & CHANGED WOOD POST NOTE	
11-30-89	RELABEL & LENGTHENED ANCHOR POST	11-30-89
3-23-89	LABELLED POSTS	514-3-23-89
1-9-87	ISSUED	535-1-9-87

**ARKANSAS STATE HIGHWAY COMMISSION**

**GUARD CABLE**

**STANDARD DRAWING GC-1**